



Founded in 1946

Project: \_\_\_\_\_

Items: \_\_\_\_\_

Quantity: \_\_\_\_\_

Approval: \_\_\_\_\_

Date: \_\_\_\_\_

## Curbside Pickup Delivery Carts

The Curb Side Pickup Delivery Carts are the perfect work station for curb side needs. The lightweight design and (2) swivel casters make it easy to move inside and outside on pavement.

### Features:

- Constructed of aluminum
- Includes writing utensil tray, paper bag holder, and hooks for plastic bags
- Manuevers easily on (4) 5" polyurethane casters, (2) swivel and (2) rigid
- Weight Capacity: 400 lbs
- Bumpers on bottom corners

### Benefits:

- Inclusion of bag holders and utensil tray make for an efficient working station
- Bumpers prevent damage to store fixtures
- Two shelf structure allows for additional storage and totes
- Light weight aluminum structure makes for easy maneuvering

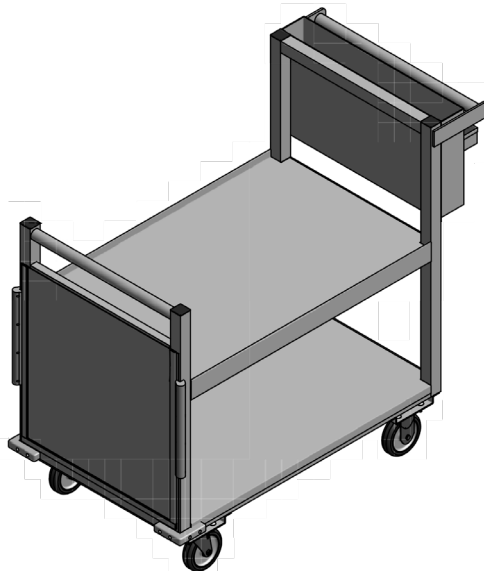

ALMCS-36-224-RCUH-HF





Founded in 1946

# Curbside Pickup Delivery Carts

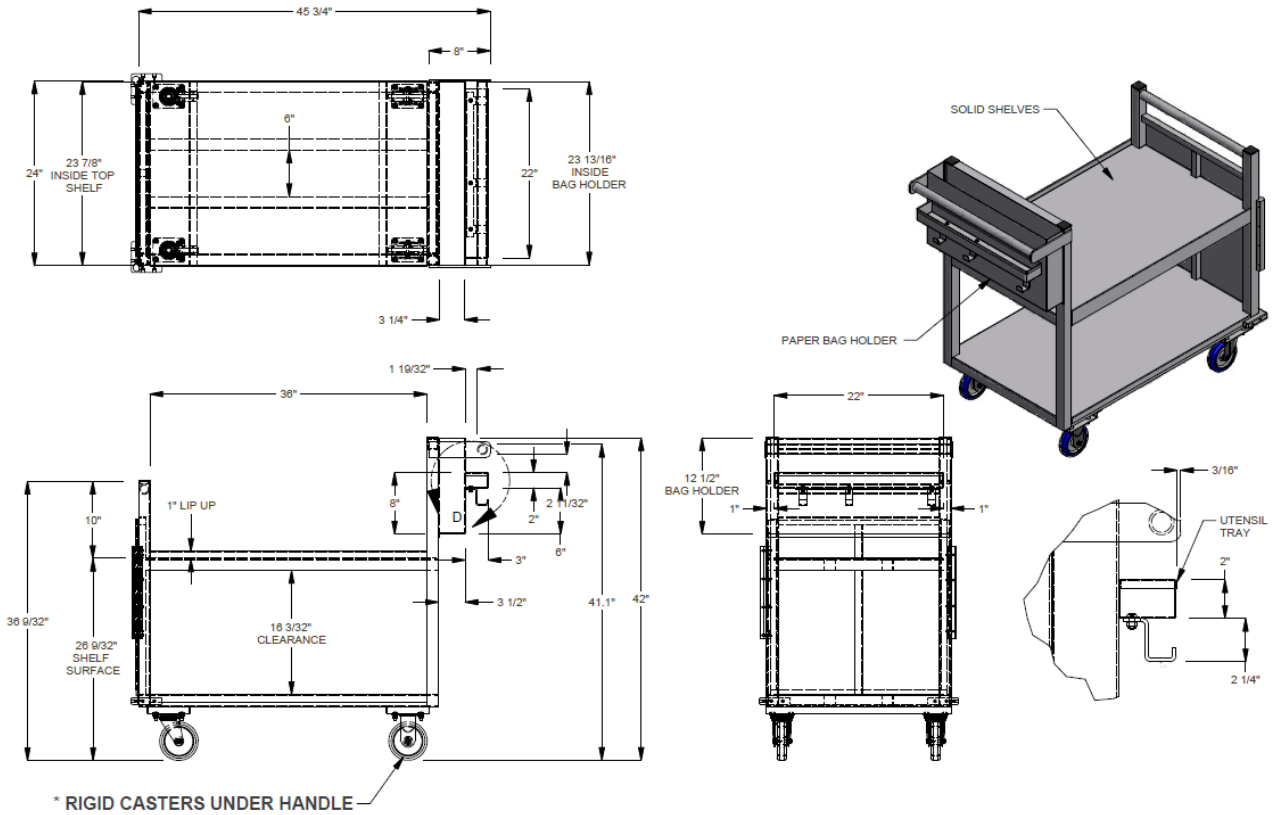

Model Number	Order#	Overall Dimensions						Approx. Ship Wt	
		Width		Length		Height			
		(in)	(mm)	(in)	(mm)	(in)	(mm)	(lb)	(kg)
ALMCS-36-224-RCUH-HF	999707	24	610	45.75	1162	42	1067	75	34

**Caster Information:**

- (2) Swivel Plate Casters with 5" Polyurethane Wheel 738AW
- (2) Rigid Plate Casters with 5" Polyurethane Wheel 743W

**Freight Class: 250**



In line with our policy to continually improve our products, Winholt reserves the right to change materials and specifications without notice.