



Project: \_\_\_\_\_  
 Items: \_\_\_\_\_  
 Quantity: \_\_\_\_\_  
 Approval: \_\_\_\_\_  
 Date: \_\_\_\_\_

## Picking Shelf Carts

The Picking Shelf Carts are an ergonomic and lean solution for faster and accurate picking and fulfillment.

### Features:

- All tubular aluminum frame construction
- 8" Polyurethane casters
- Slanted shelves
- Raised lip on shelves
- Weight Capacity: 1000 lbs

### Benefits:

- Promotes organized picking, staging, and shipping of products
- Slant shelves provide better access and greater visibility to items being picked
- Slant shelves promote first-in first-out replenishment pattern
- Raised lips on shelves ensure items are held securely in place
- Reduces the need for heavy material handling equipment
- Light weight aluminum structure makes for easy maneuvering between aisles
- Ensures one-touch picking - saving time, labor, and money.



**AL-L-6-8PU**





Founded in 1946

# Picking Shelf Carts

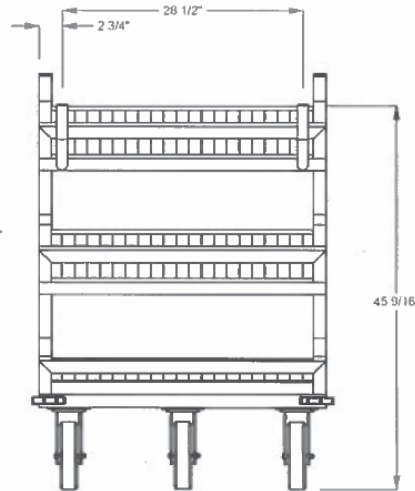
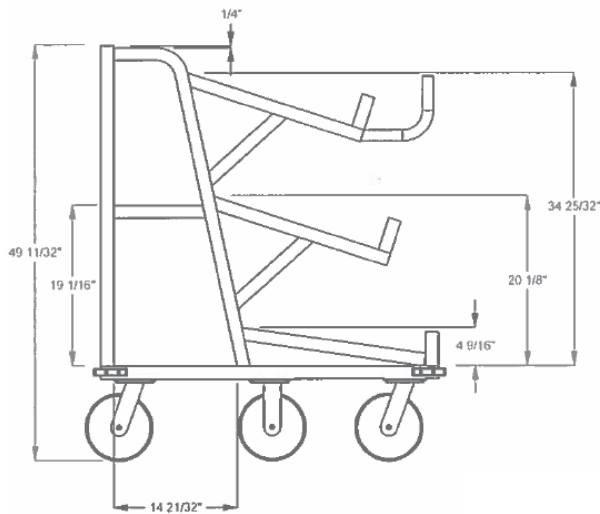
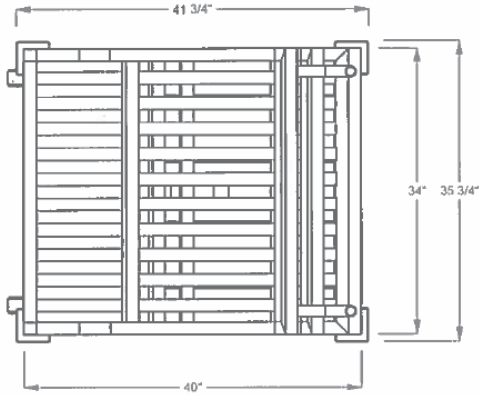

Model Number	Order#	Overall Dimensions						Approx. Ship Wt	
		Width		Length		Height			
		(in)	(mm)	(in)	(mm)	(in)	(mm)	(lb)	(kg)
AL-L-6-8PU	1075784	35.75	908	41.75	1060	49.3	1252	39	17.69

**Caster Information:**

(5) 8" Polyurethane Wheels 7325

Freight Class: 250



In line with our policy to continually improve our products, Winholt reserves the right to change materials and specifications without notice.