



Founded in 1946

Project: \_\_\_\_\_

Items: \_\_\_\_\_

Quantity: \_\_\_\_\_

Approval: \_\_\_\_\_

Date: \_\_\_\_\_

# Vending Merchandiser Kiosk Grab & Go Cart

SS-BC-2748-INSULIB-TOS

Mobile serving cart that can be used in schools, stadiums or any hospitality venue.

### Features:

- Constructed of all welded stainless steel, specifically engineered to effectively support magnetic branding and logos
- **Lifetime Warranty Against Rust**
- (3) WHPL-5K Polypropylene tubs provided
- Insulated 8" deep removable ice bin with 1" recessed drain valve. Bin holds (3) standard 12" x 20" pans.
- 5" Adjustable over shelf rack
- Removable stainless steel cover with end bumpers to prevent scratching
- Adjustable over shelf has a pin system for better sturdiness and evenness
- Includes hook to hold cover in back of the unit when not in use.
- Ergonomic handle
- (4) Lower corner bumpers
- Maneuvers easily on polyurethane casters, (2) rigid and (2) swivel with brakes.

### Benefits:

- Great for refrigerated items such as fruit, yogurt, and pastries.
- Insulated design keeps food cold
- Adjustable overshelf allows for conforming to needs and surroundings
- Sanitary and easy to clean
- Safely and efficiently transport product.



VENDING MERCHANDISER KIOSK - GRAB & GO CART

Winholt Equipment | 20 Crossways Park North, Suite 205 | Woodbury, New York 11797

Pennsylvania | Florida | Texas | California

800.444.3595 | sales@winholt.com | www.winholt.com



# Vending Merchandiser Kiosk Grab & Go Cart

Founded in 1946

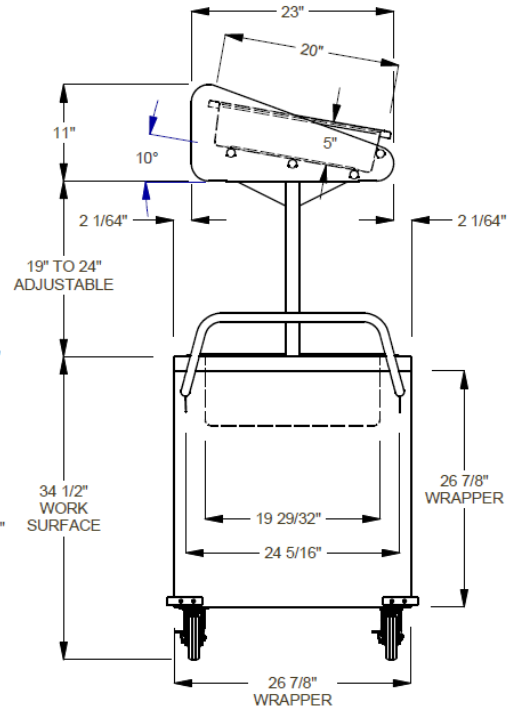
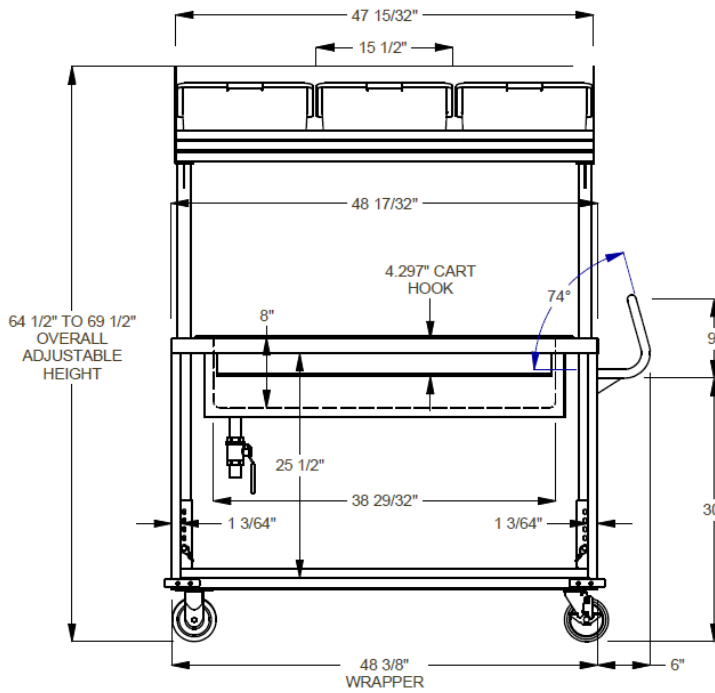
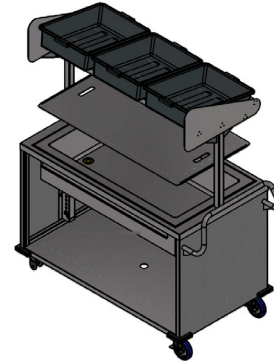
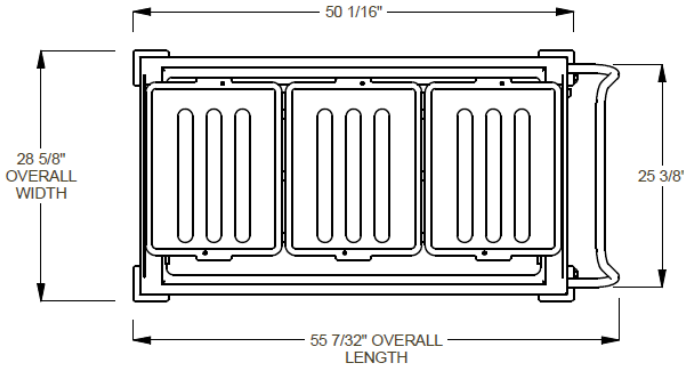

Model Number	Order#	Overall Dimensions			Approx. Ship Wt
		Width	Length	Adjustable Height	
		(in)	(in)	(in)	
SS-BC-2748-INSULIB-TOS	1152356	28.6	55.2	64.5 - 69.5	230
Tub Dimensions					
WHPL-5K	-	15.5	20	5	-

**Caster Information:**

- (2) 5" Swivel Polyurethane Casters with Brakes
- (2) 5" Rigid Polyurethane Casters

**Freight Class: 250**



In line with our policy to continually improve our products, Winholt reserves the right to change materials and specifications without notice.