



Founded in 1946

Project: _____

Items: _____

Quantity: _____

Approval: _____

Date: _____

Vending Merchandiser Kiosk K-12 Grab & Go Cart

Winholt's adjustable mobile serving cart has a reach-in, grab and go design with an adjustable height designed for students from kindergarten to twelfth grade. Use this all-in-one station to distribute fresh fruit, cold drinks, snack bags and more!

Features:

- Constructed of all welded stainless steel, specifically engineered to effectively support magnetic branding and logos
- (3) WHPL-5K Polypropylene tubs provided
- Insulated 8" deep removable ice bin with 1" recessed drain valve. Bin holds (3) standard 12" x 20" pans (not included).
- 5" Adjustable over shelf rack with pin system for better sturdiness and evenness
- Over shelf rack is removable
- Removable stainless steel cover with end bumpers to prevent scratching
- Includes hook to hold cover in back of the unit when not in use.
- Ergonomic handle
- (4) Lower corner bumpers
- Maneuvers easily on polyurethane casters, (2) rigid and (2) swivel with brakes.

Benefits:

- Insulated design is perfect for school lunch and events that include cold pre-made foods such as sandwiches, fruit bowls, salads, and more.
- 29" Surface height is ideal for young students to view and select items.
- Adjustable over shelf allows for conforming to needs and surroundings
- Mobility allows for unit to move continuously throughout an event and casters lock to keep unit in place
- Stainless steel construction is sanitary and easy to clean
- Safely and efficiently transport product.



SS-BC-2748H29-INSULIB-TOS



K-12 GRAB & GO CART



**Vending Merchandiser Kiosk
K-12 Grab & Go Cart**

Founded in 1946

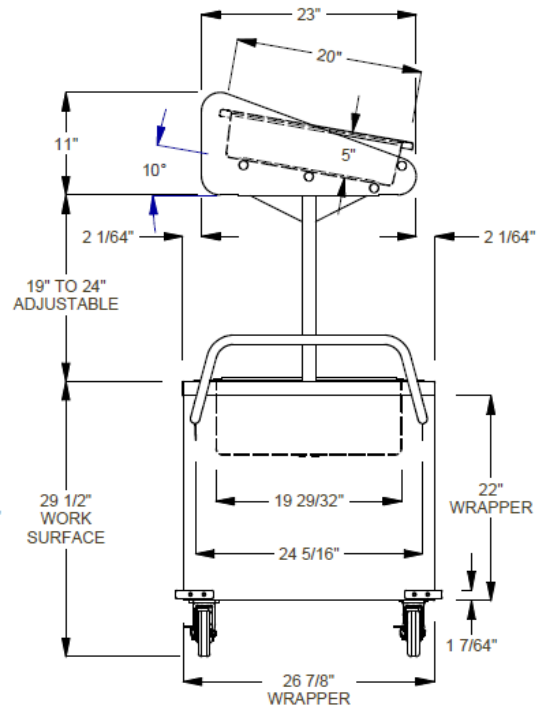
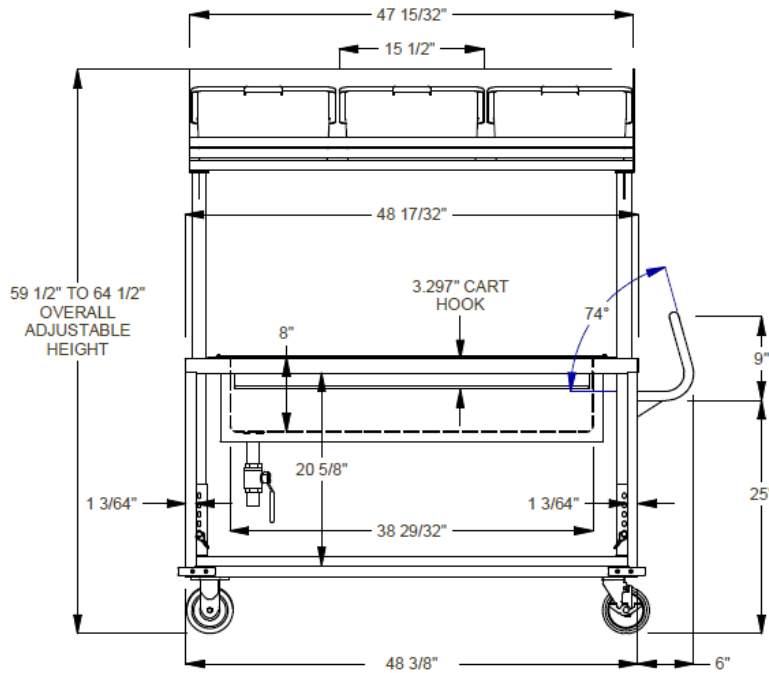
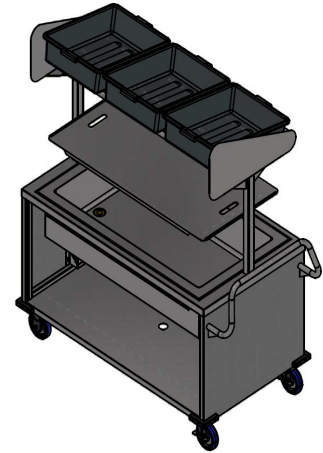
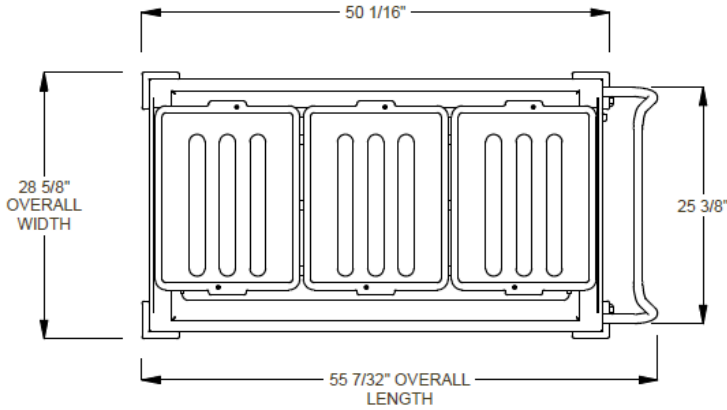

Model Number	Order#	Overall Dimensions			Approx. Ship Wt (lb)
		Width (in)	Length (in)	Adjustable Height (in)	
SS-BC-2748H29-INSULIB-TOS	1153542	28.6	55.2	59.5 - 64.5	222

Caster Information:

(2) 5" Swivel Polyurethane Casters with Brakes

(2) 5" Rigid Polyurethane Casters

Freight Class: 250



In line with our policy to continually improve our products, Winholt reserves the right to change materials and specifications without notice.