



Founded in 1946

Project: _____

Items: _____

Quantity: _____

Approval: _____

Date: _____

HEATER PROOFERS

Insulated Pass-Through Heater Proofer



This unit is designed to promote efficiency & reduce redundancy in operations by combining the function of two equipment into one & leveraging the advent of technology. Steamline grab-&-go services with pass-through double doors.

INHPL-2416-PBCAB-DGT

Features:

- Heavy duty, powder coated aluminum construction
- Forced air design
- Pass-through design with (2) field reversible lexan doors with aluminum frame, open 200°
- Dual proof/heat digital thermostatic control with temperature sensor & circuit breaker. Available with read-out LED digital display.
- Proof mode: 95% RH at 110°F
- Heat mode: max temp 180°F
- (4) Base corner bumpers
- 3" Runner spacing
- Removable digital drawer
- Can hold (16) 18" x 26", 24" x 24", or 20" x 12" pans and to-go boxes
- Electrical specifications: 120V - 60 HZ, plugs into standard 110V outlet, NEMA 5/15P, 1440 WATTS, 14 AMPS.

Benefits:

- Keep hot food warm while standing for delivery & mobile order pickup.
- Extra width specifically designed to accommodate large pizza boxes (up to 24")
- Easily and efficiently proof up to 16 pans of dough. Perfect for producing large quantities of dough such as donuts and pizza.
- Keep fresh from the oven pizza warm & ready for serving.
- Clear lexan doors allow for greater visibility of food items
- Forced air design provides even heat distribution
- Less time & effort spent closely monitoring temperature & moisture within the unit
- Easily attain accurate & precise temperature and level
- Food quality, texture & freshness are well-maintained
- Overcurrent protection to the entire equipment
- Removable digital drawer allows for easy & efficient cleaning



Winholt Equipment | 20 Crossways Park North, Suite 205 | Woodbury, New York 11797

Pennsylvania | Florida | Texas | California

800.444.3595 | sales@winholt.com | www.winholt.com



Founded in 1946

Insulated Pass-Through Heater Proofer

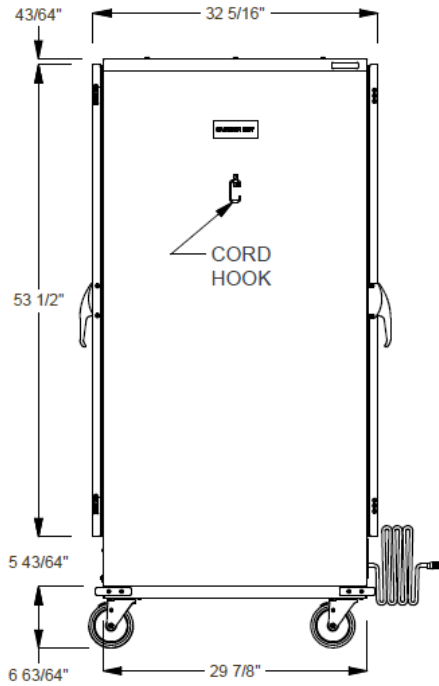
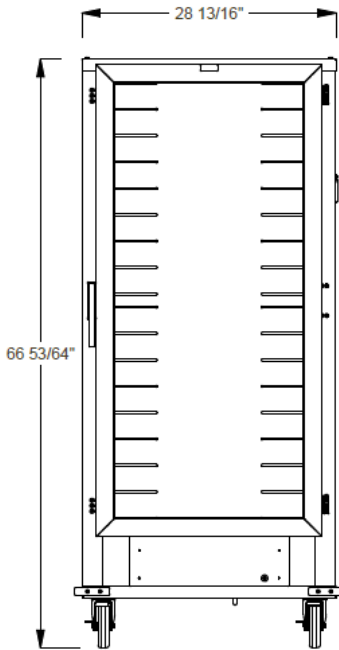
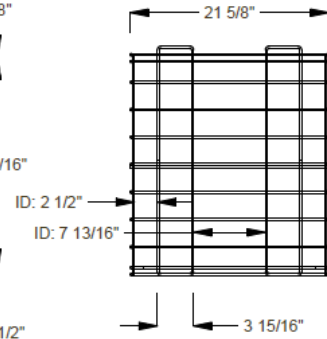
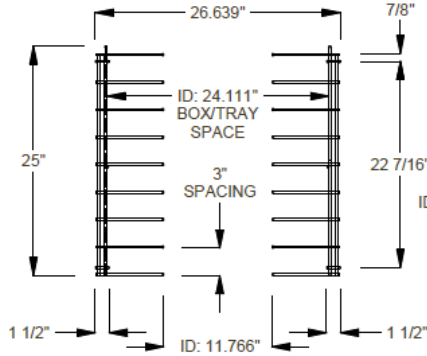
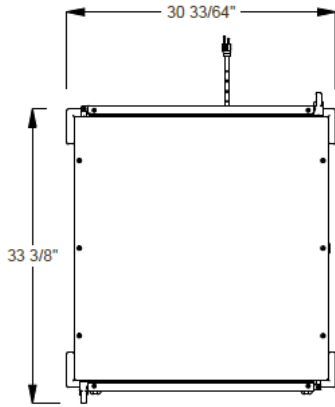

Model Number	Order#	Overall Dimensions			Approx. Ship Wt (lb)
		Width (in)	Length (in)	Height (in)	
INHPL-2416-PBCAB-DGT	1152216	30.5	33.4	66.8	154

Caster Information:

- Swivel plate caster with 5" polyurethane wheel
- Swivel plate caster with 5" polyurethane wheel and brake

Freight Class: 175



In line with our policy to continually improve our products, Winholt reserves the right to change materials and specifications without notice.